

GripTight® Test Plug Technical Specifications

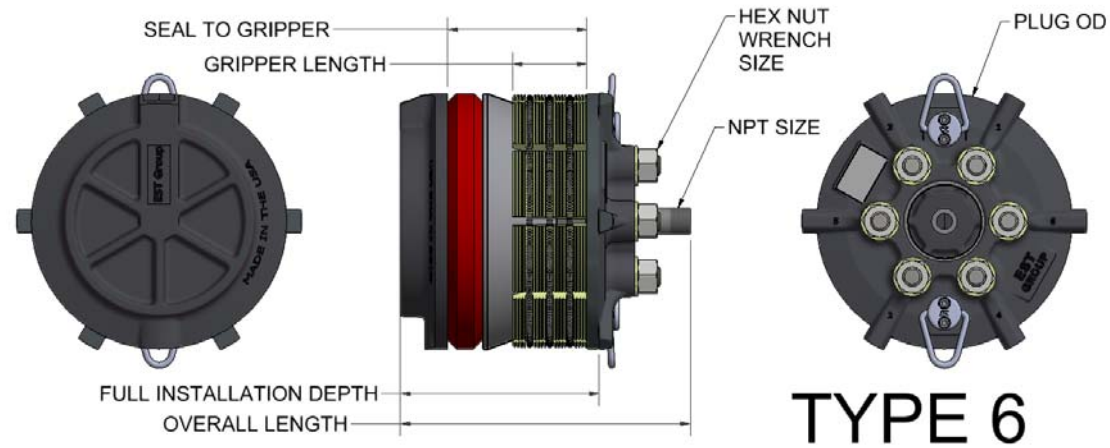

Part Number	Nominal Pipe Size	Pipe Schedule	Type	Functional I.D. Range				Plug OD		Total clearance from Min. I.D.		NPT Size	Shaft / Port I.D.		Overall Length		Seal to Gripper		Gripper Length		Full Installation Depth		Maximum Test Pressure		Number of Shafts	Hex Nut Wrench Size		Approximate Shipping Weight			
				(in)		(mm)		(in)	(mm)	(in)	(mm)		(in)	(mm)	(in)	(mm)	(in)	(mm)	(in)	(mm)	(in)	(mm)	(in)	(mm)		(in)	(mm)	(in)	(mm)	(in)	(mm)
				Min.	Max.	Min.	Max.																								
GT-10P5	10	5	6	10.45	-	10.61	265.4	-	269.5	10.32	262.1	0.13	3.3	1	0.82	20.8	13 1/8	332	5.84	148.4	2.88	73.2	9.18	233.3	707	49	4	1 - 5/8	128	58	
GT-10P10	10	10S	6	10.39	-	10.56	263.9	-	268.2	10.24	260.1	0.15	3.8	1	0.82	20.8	13 1/8	332	5.84	148.4	2.88	73.2	9.18	233.3	873	60	4	1 - 5/8	127	58	
GT-10P20	10	20	6	10.22	-	10.41	259.6	-	264.4	10.07	255.8	0.15	3.8	1	0.82	20.8	13 1/8	332	5.84	148.4	2.88	73.2	9.18	233.3	1333	92	4	1 - 5/8	123	56	
GT-10P30	10	30	6	10.10	-	10.31	256.5	-	261.9	9.96	253.0	0.14	3.6	1	0.82	20.8	13 1/8	332	5.84	148.4	2.88	73.2	9.18	233.3	1645	113	4	1 - 5/8	120	55	
GT-10P40	10	40/STD	6	9.99	-	10.21	253.7	-	259.3	9.84	249.9	0.15	3.8	1	0.82	20.8	13 1/8	332	5.84	148.4	2.88	73.2	9.18	233.3	1966	136	4	1 - 5/8	118	53	
GT-10PXS	10	XS/60	6	9.72	-	9.97	246.9	-	253.2	9.57	243.1	0.15	3.8	1	0.82	20.8	13 1/8	332	5.84	148.4	2.88	73.2	9.18	233.3	2725	188	4	1 - 5/8	112	51	
GT-10P80	10	80	6	9.48	-	9.94	240.8	-	252.5	9.38	238.3	0.10	2.5	1	0.82	20.8	13 1/8	332	5.84	148.4	2.88	73.2	9.18	233.3	3264	225	4	1 - 5/8	108	49	
GT-10P100	10	100	6	9.23	-	9.69	234.4	-	246.1	9.13	231.9	0.10	2.5	1	0.82	20.8	13 1/8	332	5.84	148.4	2.88	73.2	9.18	233.3	3993	275	4	1 - 5/8	103	47	
GT-10P120	10	120	6	9.01	-	9.47	228.9	-	240.5	8.91	226.3	0.10	2.5	3/4	0.61	15.5	9 - 7/8	251	4.72	119.9	3.00	76.2	6.23	158.3	4737	327	4	1 - 7/16	92	42	
GT-10P140	10	140	6	8.70	-	9.16	221.0	-	232.7	8.60	218.4	0.10	2.5	3/4	0.61	15.5	9 - 7/8	251	4.72	119.9	3.00	76.2	6.23	158.3	5684	392	4	1 - 7/16	86	39	
GT-10P160	10	160	6	8.45	-	8.91	214.6	-	226.3	8.35	212.1	0.10	2.5	3/4	0.61	15.5	9 - 7/8	251	4.72	119.9	3.00	76.2	6.23	158.3	6457	445	4	1 - 7/16	80	36	
GT-12P10	12	10S/5	6	12.36	-	12.57	313.9	-	319.3	12.20	309.9	0.16	4.1	1	0.82	20.8	13 1/8	332	6.33	160.8	3.37	85.6	9.74	247.3	1840	127	6	1 - 5/8	179	82	
GT-12P20	12	20	6	12.22	-	12.41	310.4	-	315.2	12.07	306.6	0.15	3.8	1	0.82	20.8	13 1/8	332	6.33	160.8	3.37	85.6	9.74	247.3	1120	77	6	1 - 5/8	175	80	
GT-12P30	12	30	6	12.06	-	12.27	306.3	-	311.7	11.91	302.5	0.15	3.8	1	0.82	20.8	13 1/8	332	6.33	160.8	3.37	85.6	9.74	247.3	1487	103	6	1 - 5/8	171	78	
GT-12P40	12	40/STD	6	11.91	-	12.19	302.5	-	309.6	11.82	300.2	0.09	2.3	1	0.82	20.8	13 1/8	332	6.33	160.8	3.37	85.6	9.74	247.3	1840	127	6	1 - 5/8	168	76	
GT-12PXS	12	XS	6	11.72	-	11.97	297.7	-	304.0	11.57	293.9	0.15	3.8	1	0.82	20.8	13 1/8	332	6.33	160.8	3.37	85.6	9.67	245.7	2282	157	4	1 - 5/8	161	73	
GT-12P60	12	60	6	11.59	-	11.86	294.4	-	301.2	11.45	290.8	0.14	3.6	1	0.82	20.8	13 1/8	332	6.33	160.8	3.37	85.6	9.67	245.7	2577	178	4	1 - 5/8	157	72	
GT-12P80	12	80	6	11.34	-	11.64	288.0	-	295.7	11.19	284.2	0.15	3.8	1	0.82	20.8	13 1/8	332	6.33	160.8	3.37	85.6	9.67	245.7	3714	256	4	1 - 5/8	150	68	
GT-12P100	12	100	6	11.03	-	11.37	280.2	-	288.8	10.88	276.4	0.15	3.8	1	0.82	20.8	13 1/8	332	5.84	148.4	2.88	73.2	9.18	233.3	3950	272	4	1 - 5/8	142	65	
GT-12P120	12	120/XXS	6	10.72	-	11.09	272.3	-	281.7	10.57	268.5	0.15	3.8	1	0.82	20.8	13 1/8	332	5.84	148.4	2.88	73.2	9.18	233.3	4732	326	4	1 - 5/8	134	61	
GT-12P140	12	140	6	10.47	-	10.88	265.9	-	276.4	10.32	262.1	0.15	3.8	1	0.82	20.8	13 1/8	332	5.84	148.4	2.88	73.2	9.18	233.3	5369	370	4	1 - 5/8	128	58	
GT-12P160	12	160	6	10.06	-	10.52	255.5	-	267.2	9.96	253.0	0.10	2.5	1	0.82	20.8	13 1/8	332	5.84	148.4	2.88	73.2	9.18	233.3	6340	437	4	1 - 5/8	120	55	

Questions? Contact EST Group Customer Service at any of the following locations.



EST Group

www.cw-estgroup.com

North, Central & South America

EST Group Corporate Office
2701 Township Line Road
Hatfield, PA 19440-1770 USA
P: +1.215.721.1100
+1.800.355.7044
F: +1.215.721.1101
est-info@curtisswright.com

Europe / Middle East / Africa

EST Group B.V.
Hoorn 312a
2404 HL Alphen aan den Rijn
The Netherlands
P: +31.172.418841
F: +31.172.418849
est-emea@curtisswright.com

China

P +86.400.636.5077
est-china@curtisswright.cn

Singapore

P +65.3158.5052
est-asia@curtisswright.com

GripTight® Test Plug Technical Specifications

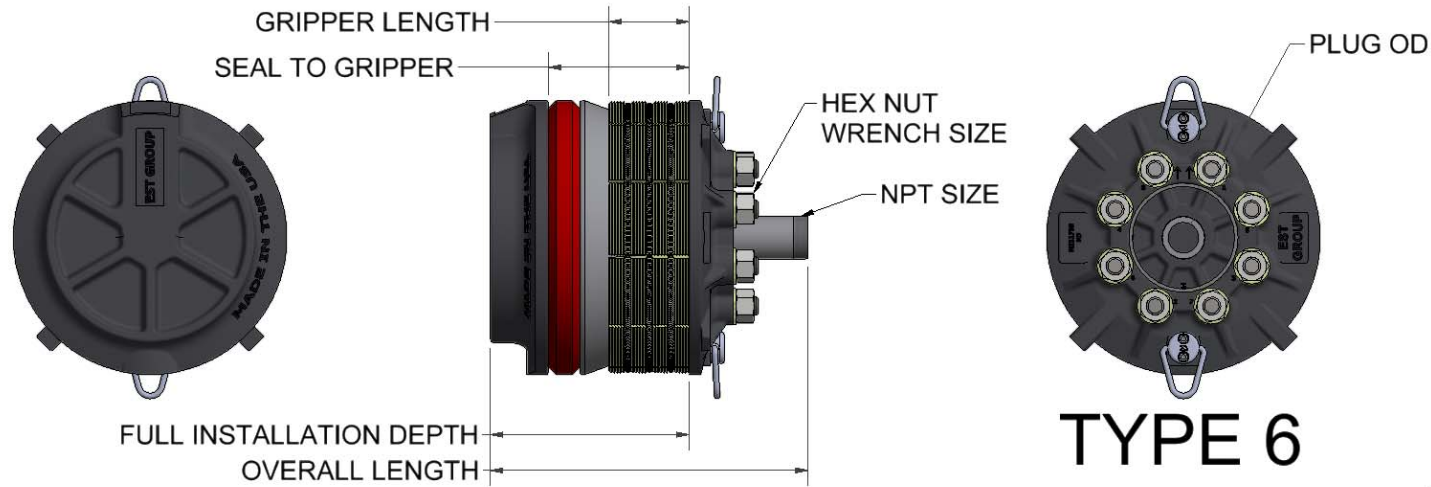

Part Number	Nominal Pipe Size	Pipe Schedule	Type	Functional I.D. Range				Plug OD		Total clearance from Min. I.D.		NPT Size	Shaft / Port I.D.		Overall Length		Seal to Gripper		Gripper Length		Full Installation Depth		Maximum Test Pressure		Number of Shafts	Hex Nut Wrench Size	Approximate Shipping Weight					
				(in)		(mm)		(in)	(mm)	(in)	(mm)		(in)	(mm)	(in)	(mm)	(in)	(mm)	(in)	(mm)	(in)	(mm)	(in)	(mm)			(in)	(mm)	(in)	(mm)	(in)	(mm)
				Min.	Max.	Min.	Max.																									
GT-14P10	14	10	6	13.47	-	13.82	342.1	-	351.0	13.31	338.1	0.16	4.1	1	0.82	20.8	13 1/8	331.8	6.86	174.2	3.73	94.7	10.26	260.7	1018	70	6	1 - 5/8	216	98		
GT-14P20	14	20	6	13.34	-	13.55	338.8	-	344.2	13.20	335.3	0.14	3.6	1	0.82	20.8	13 1/8	331.8	6.86	174.2	3.73	94.7	10.26	260.7	12.76	1	6	1 - 5/8	212	96		
GT-14P30	14	STD/ 30	6	13.22	-	13.44	335.8	-	341.4	13.07	332.0	0.15	3.8	1	0.82	20.8	13 1/8	331.8	6.86	174.2	3.73	94.7	10.26	260.7	1540	106	6	1 - 5/8	208	94		
GT-14P40	14	40	6	13.09	-	13.33	332.5	-	338.6	12.94	328.7	0.15	3.8	1	0.82	20.8	13 1/8	331.8	6.86	174.2	3.73	94.7	10.26	260.7	1807	125	6	1 - 5/8	203	92		
GT-14PXS	14	XS	6	12.97	-	13.22	329.4	-	335.8	12.82	325.6	0.15	3.8	1	0.82	20.8	13 1/8	331.8	6.86	174.2	3.73	94.7	10.26	260.7	2071	143	6	1 - 5/8	199	91		
GT-14P60	14	60	6	12.78	-	13.05	324.6	-	331.5	12.63	320.8	0.15	3.8	1	0.82	20.8	13 1/8	331.8	6.86	174.2	3.73	94.7	10.26	260.7	2476	171	6	1 - 5/8	193	88		
GT-14P80	14	80	6	12.47	-	12.78	316.7	-	324.6	12.32	312.9	0.15	3.8	1	0.82	20.8	13 1/8	331.8	6.86	174.2	3.73	94.7	10.26	260.7	3160	218	6	1 - 5/8	183	83		
GT-14P100	14	100	6	12.09	-	12.45	307.1	-	316.2	11.94	303.3	0.15	3.8	1	0.82	20.8	13 1/8	331.8	6.33	160.8	3.37	85.6	9.74	247.3	4001	276	6	1 - 5/8	172	78		
GT-14P120	14	120	6	11.78	-	12.18	299.2	-	309.4	11.63	295.4	0.15	3.8	1	0.82	20.8	13 1/8	331.8	6.33	160.8	3.37	85.6	9.67	245.7	4713	325	4	1 - 5/8	163	74		
GT-14P140	14	140	6	11.47	-	11.91	291.3	-	302.5	11.32	287.5	0.15	3.8	1	0.82	20.8	13 1/8	331.8	6.33	160.8	3.37	85.6	9.67	245.7	5438	375	4	1 - 5/8	154	70		
GT-14P160	14	160	6	11.10	-	11.56	281.9	-	293.6	11.00	279.4	0.10	2.5	1	0.82	20.8	13 1/8	331.8	6.33	160.8	3.37	85.6	8.67	220.3	6175	426	4	1 - 5/8	145	66		
GT-16P10	16	10	6	15.47	-	15.81	392.9	-	401.6	15.32	389.1	0.15	3.8	2	1.69	42.9	17 - 1/2	444.5	7.73	196.3	4.40	111.8	11.91	302.6	889	61	8	1 - 5/8	315	143		
GT-16P20	16	20	6	15.34	-	15.55	389.6	-	395.0	15.20	386.1	0.14	3.6	2	1.69	42.9	17 - 1/2	444.5	7.73	196.3	4.40	111.8	11.91	302.6	1113	77	8	1 - 5/8	307	140		
GT-16PSTD	16	STD/30	6	15.22	-	5.44	386.6	-	138.2	15.07	382.8	0.15	3.8	2	1.69	42.9	17 - 1/2	444.5	7.73	196.3	4.40	111.8	11.91	302.6	1343	93	8	1 - 5/8	298	135		
GT-16PXS	16	40/XS	6	14.98	-	15.22	380.5	-	386.6	14.82	376.4	0.16	4.1	2	1.69	42.9	17 - 1/2	444.5	7.73	196.3	4.40	111.8	11.91	302.6	1805	124	8	1 - 5/8	280	127		
GT-16P60	16	60	6	14.66	-	14.95	372.4	-	379.7	14.51	368.6	0.15	3.8	2	1.69	42.9	17 - 1/2	444.5	7.73	196.3	4.40	111.8	11.91	302.6	2390	165	8	1 - 5/8	258	117		
GT-16P80	16	80	6	14.28	-	14.62	362.7	-	371.3	14.13	358.9	0.15	3.8	1	0.82	20.8	15 1/8	382.6	7.53	191.2	4.40	111.8	10.93	277.7	3109	214	6	1 - 5/8	246	112		
GT-16P100	16	100	6	13.91	-	14.29	353.3	-	363.0	13.76	349.5	0.15	3.8	1	0.82	20.8	15 1/8	382.6	7.53	191.2	4.40	111.8	10.93	277.7	3839	265	6	1 - 5/8	232	106		
GT-16P120	16	120	6	13.53	-	13.96	343.7	-	354.6	13.38	339.9	0.15	3.8	1	0.82	20.8	13 1/8	331.8	6.86	174.2	3.73	94.7	10.26	260.7	4587	316	6	1 - 5/8	218	99		
GT16P140	16	140	6	13.09	-	13.58	332.5	-	344.9	12.94	328.7	0.15	3.8	1	0.82	20.8	13 1/8	331.8	6.86	174.2	3.73	94.7	10.26	260.7	5477	378	6	1 - 5/8	203	92		
GT-16P160	16	160	6	12.78	-	13.30	324.6	-	337.8	12.63	320.8	0.15	3.8	1	0.82	20.8	13 1/8	331.8	6.86	174.2	3.73	94.7	10.26	260.7	6121	422	6	1 - 5/8	193	88		

Questions? Contact EST Group Customer Service at any of the following locations.



EST Group

www.cw-estgroup.com

North, Central & South America

EST Group Corporate Office
2701 Township Line Road
Hatfield, PA 19440-1770 USA
P: +1.215.721.1100
+1.800.355.7044
F: +1.215.721.1101
est-info@curtisswright.com

Europe / Middle East / Africa

EST Group B.V.
Hoorn 312a
2404 HL Alphen aan den Rijn
The Netherlands
P: +31.172.418841
F: +31.172.418849
est-emea@curtisswright.com

China

P +86.400.636.5077
est-china@curtisswright.cn

Singapore

P +65.3158.5052
est-asia@curtisswright.com

GripTight® Test Plug Technical Specifications

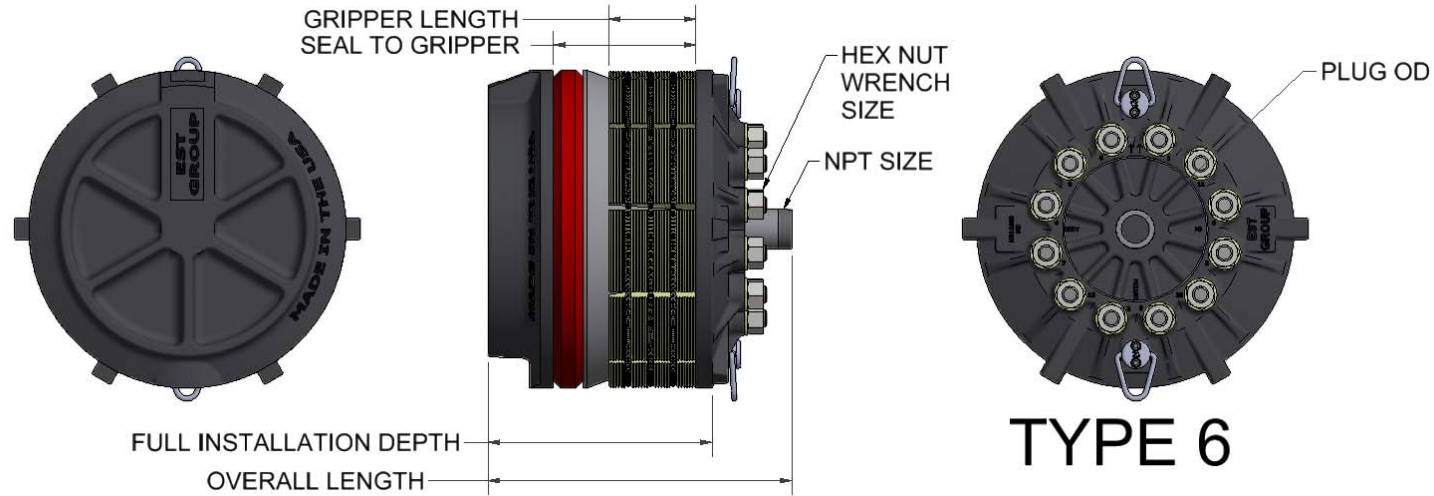

Part Number	Nominal Pipe Size	Pipe Schedule	Type	Functional I.D. Range				Plug OD		Total clearance from Min. I.D.		NPT Size	Shaft / Port I.D.		Overall Length		Seal to Gripper		Gripper Length		Full Installation Depth		Maximum Test Pressure		Number of Shafts	Hex Nut Wrench Size	Approximate Shipping Weight	
				(in)		(mm)		(in)	(mm)	(in)	(mm)		(in)	(mm)	(in)	(mm)	(in)	(mm)	(in)	(mm)	(PsiG)	(BarG)	(in)	(lbs)			(kg)	
				Min.	Max.	Min.	Max.																					
GT-18P10	18	10	6	17.46	17.81	443.5	452.4	17.32	439.9	0.14	3.6	2	1.69	42.9	18 - 1/4	463.6	8.12	206.3	4.74	120.4	12.31	312.7	789	54	10	1 - 5/8	445	202
GT-18P20	18	20	6	17.34	17.55	440.4	445.8	17.20	436.9	0.14	3.6	2	1.69	42.9	18 - 1/4	463.6	8.12	206.3	4.74	120.4	12.31	312.7	987	68	10	1 - 5/8	438	199
GT-18PSTD	18	STD	6	17.22	17.44	437.4	443.0	17.07	433.6	0.15	3.8	2	1.69	42.9	18 - 1/4	463.6	8.12	206.3	4.74	120.4	12.31	312.7	1191	82	10	1 - 5/8	430	195
GT-18P30	18	30	6	17.09	17.33	434.1	440.2	16.94	430.3	0.15	3.8	2	1.69	42.9	18 - 1/4	463.6	8.12	206.3	4.74	120.4	12.31	312.7	1396	96	10	1 - 5/8	422	192
GT-18PXS	18	XS	6	16.97	17.22	431.0	437.4	16.82	427.2	0.15	3.8	2	1.69	42.9	18 - 1/4	463.6	8.12	206.3	4.74	120.4	12.31	312.7	1599	110	10	1 - 5/8	414	188
GT-18P40	18	40	6	16.84	17.11	427.7	434.6	16.70	424.2	0.14	3.6	2	1.69	42.9	18 - 1/4	463.6	8.12	206.3	4.74	120.4	12.31	312.7	1803	124	10	1 - 5/8	407	185
GT-18P60	18	60	6	16.47	16.78	418.3	426.2	16.32	414.5	0.15	3.8	2	1.69	42.9	18 - 1/4	463.6	8.12	206.3	4.74	120.4	12.31	312.7	2430	168	10	1 - 5/8	383	174
GT-18P80	18	80	6	16.09	16.45	408.7	417.8	15.94	404.9	0.15	3.8	2	1.69	42.9	17 - 1/2	444.5	8.12	206.3	4.74	120.4	12.31	312.7	3069	212	8	1 - 5/8	358	163
GT-18P100	18	100	6	15.66	16.07	397.8	408.2	15.51	394.0	0.15	3.8	2	1.69	42.9	17 - 1/2	444.5	7.73	196.3	4.40	111.8	11.91	302.6	3825	264	8	1 - 5/8	329	149
GT-18P120	18	120	6	15.22	15.69	386.6	398.5	15.07	382.8	0.15	3.8	2	1.69	42.9	17 - 1/2	444.5	7.73	196.3	4.40	111.8	11.91	302.6	4600	317	8	1 - 5/8	298	135
GT-18P140	18	140	6	14.84	15.36	376.9	390.1	14.69	373.1	0.15	3.8	2	1.69	42.9	17 - 1/2	444.5	7.73	196.3	4.40	111.8	11.91	302.6	5274	364	8	1 - 5/8	271	123
GT-18P160	18	160	6	14.41	14.98	366.0	380.5	14.25	362.0	0.16	4.1	2	1.69	42.9	17 - 1/2	444.5	7.73	196.3	4.40	111.8	11.91	302.6	6076	419	8	1 - 5/8	239	108
GT-20P10	20	10/10S/5	6	19.47	19.80	494.5	502.9	19.38	492.3	0.09	2.3	2	1.69	42.9	18 - 1/4	463.6	8.62	219.0	5.24	133.1	12.81	325.4	709	49	12	1 - 5/8	560	255
GT-20PSTD	20	STD/20	6	19.22	19.47	488.2	494.5	19.07	484.4	0.15	3.8	2	1.69	42.9	18 - 1/4	463.6	8.62	219.0	5.24	133.1	12.81	325.4	1070	74	12	1 - 5/8	544	247
GT-20PXS	20	XS/30	6	18.97	19.25	481.8	489.0	18.82	478.0	0.15	3.8	2	1.69	42.9	18 - 1/4	463.6	8.62	219.0	5.24	133.1	12.81	325.4	1435	99	12	1 - 5/8	531	241
GT-20P40	20	40	6	18.78	19.09	477.0	484.9	18.63	473.2	0.15	3.8	2	1.69	42.9	18 - 1/4	463.6	8.62	219.0	5.24	133.1	12.81	325.4	1713	118	12	1 - 5/8	520	237
GT-20P60	20	60	6	18.34	18.70	465.8	475.0	18.20	462.3	0.14	3.6	2	1.69	42.9	18 - 1/4	463.6	8.62	219.0	5.24	133.1	12.81	325.4	2366	163	10	1 - 5/8	497	226
GT-20P80	20	80	6	17.91	18.32	454.9	465.3	17.76	451.1	0.15	3.8	2	1.69	42.9	18 - 1/4	463.6	8.62	219.0	5.24	133.1	12.81	325.4	3035	209	10	1 - 5/8	471	214
GT-20P100	20	100	6	17.41	17.88	442.2	454.2	17.26	438.4	0.15	3.8	2	1.69	42.9	18 - 1/4	463.6	8.12	206.3	4.74	120.4	12.31	312.7	3814	263	10	1 - 5/8	442	201
GT-20P120	20	120	6	16.97	17.50	431.0	444.5	16.82	427.2	0.15	3.8	2	1.69	42.9	18 - 1/4	463.6	8.12	206.3	4.74	120.4	12.31	312.7	4511	311	10	1 - 5/8	414	188
GT-20P140	20	140	6	16.47	17.06	418.3	433.3	16.32	414.5	0.15	3.8	2	1.69	42.9	18 - 1/4	463.6	8.12	206.3	4.74	120.4	12.31	312.7	5321	367	10	1 - 5/8	383	174
GT-20P160	20	160	6	16.03	16.68	407.2	423.7	15.87	403.1	0.16	4.1	2	1.69	42.9	17 - 1/2	444.5	8.12	206.3	4.74	120.4	12.31	312.7	6043	417	8	1 - 5/8	353	160

Questions? Contact EST Group Customer Service at any of the following locations.



EST Group

www.cw-estgroup.com

North, Central & South America

EST Group Corporate Office
2701 Township Line Road
Hatfield, PA 19440-1770 USA
P: +1.215.721.1100
+1.800.355.7044
F: +1.215.721.1101
est-info@curtisswright.com

Europe / Middle East / Africa

EST Group B.V.
Hoorn 312a
2404 HL Alphen aan den Rijn
The Netherlands
P: +31.172.418841
F: +31.172.418849
est-emea@curtisswright.com

China

P +86.400.636.5077
est-china@curtisswright.cn

Singapore

P +65.3158.5052
est-asia@curtisswright.com

GripTight® Test Plug Technical Specifications

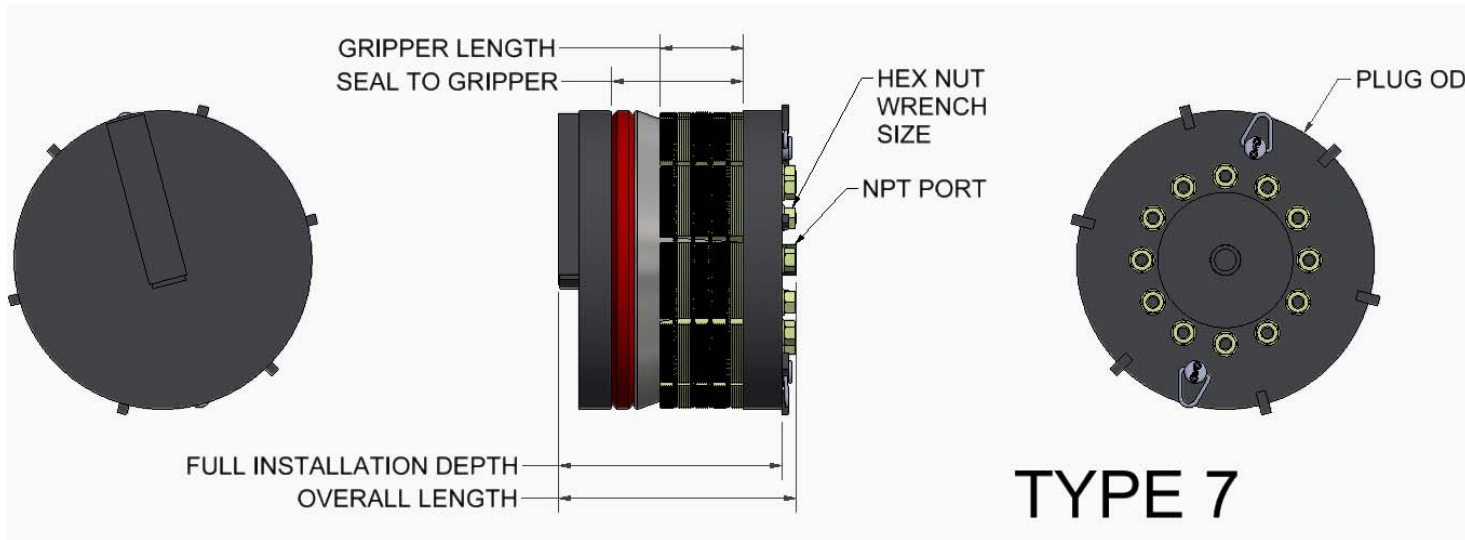

Part Number	Nominal Pipe Size	Pipe Schedule	Type	Functional I.D. Range				Plug OD		Total clearance from Min. I.D.		NPT Size	Shaft / Port I.D.		Overall Length		Seal to Gripper		Gripper Length		Full Installation Depth		Maximum Test Pressure		Number of Shafts	Hex Nut Wrench Size	Approximate Shipping Weight			
				(in)		(mm)		(in)	(mm)	(in)	(mm)		(in)	(mm)	(in)	(mm)	(in)	(mm)	(in)	(mm)	(in)	(mm)	(in)	(mm)			(in)	(mm)	(in)	(mm)
				Min.	Max.	Min.	Max.																							
GT-22P10	22	10/10S/5	7	21.47	-	21.80	545.3	-	553.7	21.25	539.8	0.22	5.6	2	1.69	42.9	17 - 3/4	450.9	10.09	256.2	6.43	163.3	15.50	393.7	644	44	12	1 - 5/8	850	386
GT-22PSTD	22	20/STD	7	21.22	-	21.47	539.0	-	545.3	21.00	533.4	0.22	5.6	2	1.69	42.9	17 - 3/4	450.9	10.09	256.2	6.43	163.3	15.50	393.7	971	67	12	1 - 5/8	850	386
GT-22PXS	22	XS	7	20.97	-	21.25	532.6	-	539.8	20.75	527.1	0.22	5.6	2	1.69	42.9	18 - 3/4	476.3	10.09	256.2	6.43	163.3	16.00	406.4	1302	90	12	1 - 5/8	850	386
GT-22P60	22	60	6	20.22	-	20.59	513.6	-	523.0	20.03	508.8	0.19	4.8	2	1.69	42.9	18 - 1/4	463.6	9.45	240.0	5.93	150.6	13.64	346.4	2316	160	12	1 - 5/8	592	269
GT-22P80	22	80	6	19.72	-	20.16	500.9	-	512.1	19.53	496.1	0.19	4.8	2	1.69	42.9	18 - 1/4	463.6	9.45	240.0	5.93	150.6	13.64	346.4	3009	208	12	1 - 5/8	568	258
GT-22P100	22	100	6	19.22	-	19.72	488.2	-	500.9	19.07	484.4	0.15	3.8	2	1.69	42.9	18 - 1/4	463.6	8.62	219.0	5.24	133.1	12.81	325.4	3814	263	12	1 - 5/8	544	247
GT-22P120	22	120	6	18.72	-	19.28	475.5	-	489.7	18.58	471.9	0.14	3.6	2	1.69	42.9	18 - 1/4	463.6	8.62	219.0	5.24	133.1	12.81	325.4	4438	306	12	1 - 5/8	518	235
GT-22P140	22	140	6	18.22	-	18.48	462.8	-	469.4	18.06	458.7	0.16	4.1	2	1.69	42.9	18 - 1/4	463.6	8.62	219.0	5.24	133.1	12.81	325.4	5172	357	10	1 - 5/8	489	222
GT-22P160	22	160	6	17.72	-	18.41	450.1	-	467.6	17.55	445.8	0.17	4.3	2	1.69	42.9	18 - 1/4	463.6	8.62	219.0	5.24	133.1	12.81	325.4	5920	408	10	1 - 5/8	459	209
GT-24P10	24	10/10S/5	7	23.47	-	23.74	596.1	-	603.0	23.31	592.1	0.16	4.1	2	1.69	42.9	21 - 7/8	555.8	10.09	256.2	6.43	163.3	16.63	422.3	589	41	12	1 - 5/8	1100	500
GT-24PSTD	24	20/STD	7	23.22	-	23.47	589.8	-	596.1	23.00	584.2	0.22	5.6	2	1.69	42.9	21 - 7/8	555.8	10.09	256.2	6.43	163.3	16.63	422.3	889	61	12	1 - 5/8	1100	500
GT-24PXS	24	XS	7	22.97	-	23.25	583.4	-	590.6	22.75	577.9	0.22	5.6	2	1.69	42.9	18 - 3/4	476.3	10.09	256.2	6.43	163.3	17.50	444.5	1191	82	12	1 - 5/8	1100	500
GT-24P30	24	30	7	22.84	-	23.14	580.1	-	587.8	22.63	574.8	0.21	5.3	2	1.69	42.9	18 - 3/4	476.3	10.09	256.2	6.43	163.3	17.50	444.5	13442	927	12	1 - 5/8	1100	500
GT-24P40	24	40	7	22.59	-	22.92	573.8	-	582.2	22.37	568.2	0.22	5.6	2	1.69	42.9	18 - 3/4	476.3	10.09	256.2	6.43	163.3	17.25	438.2	1651	114	12	1 - 5/8	1100	500
GT-24P60	24	60	7	22.03	-	22.43	559.6	-	569.7	21.81	554.0	0.22	5.6	2	1.69	42.9	18 - 3/4	476.3	10.09	256.2	6.43	163.3	17.25	438.2	2352	162	12	1 - 5/8	1100	500
GT-24P80	24	80	7	21.53	-	21.99	546.9	-	558.5	21.31	541.3	0.22	5.6	2	1.69	42.9	18 - 3/4	476.3	10.09	256.2	6.43	163.3	17.00	431.8	2985	206	12	1 - 5/8	1100	500
GT-24P100	24	100	6	20.91	-	21.45	531.1	-	544.8	20.72	526.3	0.19	4.8	2	1.69	42.9	18 - 1/4	463.6	9.45	240.0	5.93	150.6	13.64	346.4	3798	262	12	1 - 5/8	624	284
GT-24P120	24	120	6	20.34	-	20.95	516.6	-	532.1	20.16	512.1	0.18	4.6	2	1.69	42.9	18 - 1/4	463.6	9.45	240.0	5.93	150.6	13.64	346.4	4543	313	12	1 - 5/8	598	272
GT-24P140	24	140	6	19.84	-	20.52	503.9	-	521.2	19.66	499.4	0.18	4.6	2	1.69	42.9	18 - 1/4	463.6	9.45	240.0	5.93	150.6	13.64	346.4	5217	360	12	1 - 5/8	574	261
GT-24P160	24	160	6	19.28	-	20.02	489.7	-	508.5	19.13	485.9	0.15	3.8	2	1.69	42.9	18 - 1/4	463.6	8.62	219.0	5.24	133.1	12.81	325.4	5991	413	12	1 - 5/8	547	249

Questions? Contact EST Group Customer Service at any of the following locations.



EST Group

www.cw-estgroup.com

North, Central & South America

EST Group Corporate Office

2701 Township Line Road
Hatfield, PA 19440-1770 USA
P: +1.215.721.1100

+1.800.355.7044

F: +1.215.721.1101

est-info@curtisswright.com

Europe / Middle East / Africa

EST Group B.V.

Hoorn 312a
2404 HL Alphen aan den Rijn
The Netherlands
P: +31.172.418841

F: +31.172.418849

est-emea@curtisswright.com

China

P +86.400.636.5077

est-china@curtisswright.cn

Singapore

P +65.3158.5052

est-asia@curtisswright.com