

OPERATING PROCEDURES FOR G-160 TUBE TESTING TOOLS

1. PRIOR TO TESTING:

- 1.1. The tubes to be tested should be cleaned and any loose deposits or scale should be removed. If the tubes have not been cleaned, any foreign materials present may be ejected during the testing operation and may damage the test tools or injure the operators.
- 1.2. The operators should always wear safety glasses or a face shield when testing with the G-160 Tube Testing Tool or any type of pressure test tools.
- 1.3. If the tubes have been chemically cleaned please check with EST Customer Service regarding the compatibility of the G-160 Tube Testing Tool Seals with the cleaning agent. Alternate seal materials are available.
- 1.4. Verify tube size to be tested.
- 1.5. Make sure the G-160 Tube Testing Tools have the correct size Seal and Washer Set (2) for the tubes being tested. The Seals and Washers are correctly sized if the OD of the Seals are 0.02" to 0.06" (0.51 mm to 1.52 mm) smaller than the actual tube ID.

Using Seals that are too small may cause any of the following:

- Premature Seal wear
- Jamming of the G-160 Tube Testing Tool in the tube
- Expulsion of the G-160 Tube Testing Tool from the tube end

Replacement Seals for the G-160 Tube Testing Tools can be procured for any tube I.D. from 0.28" to 1.81" (7.11 mm to 46.00 mm). For tube ID's larger than 1.81" (46.00 mm), contact EST.

The procedure for replacing the Seal and Washer sets is outlined in section 3.

Questions? Contact EST Group Customer Service at any of the following locations.

**CURTISS -
WRIGHT**

EST Group
www.cw-estgroup.com

North, Central & South America
EST Group Corporate Office
2701 Township Line Road
Hatfield, PA 19440-1770 USA
P: +1.215.721.1100
+1.800.355.7044
F: +1.215.721.1101
est-info@curtisswright.com

Europe / Middle East / Africa
EST Group B.V.
Hoorn 312a
2404 HL Alphen aan den Rijn
The Netherlands
P: +31.172.418841
F: +31.172.418849
est-emea@curtisswright.com

China
P +86.400.636.5077
est-china@curtisswright.cn

Singapore
P +65.3158.5052
est-asia@curtisswright.com

1.6. If testing tube ID's from 0.28 to 0.48" (7.11 to 12.19 mm) the Regulator Assembly (part number GSA-REG) is required. Regulator is sold separately.



1.7. For testing tube ID's 0.86" and larger, gripper GSA-1642, GSA-1643 or GSA-1644 are required. The grippers are included in G-160 Support Tube Assemblies GSA-1612, GSA-1613 and GSA-1614.

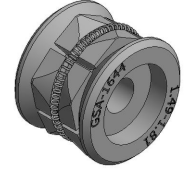

1.8. If using grippers, apply a lubricant such as Molykote® DX or SAE 10W motor oil to the tapered surface of the Gripper Assembly Cone. Wipe away any excess lubricant from components making sure to leave an ample amount on tapered cone face and mating surface of gripper back. Lubricant must not be on seal.

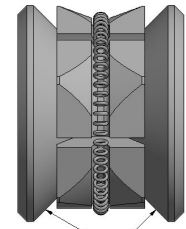

APPLY A LIGHT LUBRICANT

2. TESTING PROCEDURE:

WARNING: Never actuate the G-160 Tube Testing Injection Tool unless the Seal Assembly is installed within the proper ID tube as the Washers could be forced into the Seal ID. This could damage the Seals.

The G-160 Tube Testing Tools come as a set. This set is comprised of an Injection Tool and a Plugging Tool. The Injection Tool can be differentiated from the Plugging Tool because it incorporates the Cartridge Valve (7). The Plugging Tool will not operate without the Injection Tool.



2.1. Attach air supply to the Injection Tool. The G-160 Tube Testing Tools can be operated on plant air supplies ranging from 40 to 125 PsiG (2.7 to 8.6 BarG) at a minimum of 5 cfm. If testing tube ID's from 0.28 to 0.48" (7.11 to 12.19 mm) the Regulator Assembly (part number GSA-REG) is required. Install Regulator Assembly (16) with arrow pointing towards the Injection Tool onto bottom of the housing handle (14) (use 1/4"NPT nipple (16a), included in the Regulator Assembly) and attach air supply to Regulator Assembly input. For tube ID's from 0.28" - 0.48" (7.11 mm – 12.19 mm) adjust regulator to 40 – 60 PsiG (2.7 to 4.1 BarG) by rotating adjustment knobs while viewing gauge.



Questions? Contact EST Group Customer Service at any of the following locations.

**CURTISS -
WRIGHT**

EST Group
www.cw-estgroup.com

North, Central & South America
EST Group Corporate Office
2701 Township Line Road
Hatfield, PA 19440-1770 USA
P: +1.215.721.1100
+1.800.355.7044
F: +1.215.721.1101
est-info@curtisswright.com

Europe / Middle East / Africa
EST Group B.V.
Hoorn 312a
2404 HL Alphen aan den Rijn
The Netherlands
P: +31.172.418841
F: +31.172.418849
est-emea@curtisswright.com

China
P +86.400.636.5077
est-china@curtisswright.cn

Singapore
P +65.3158.5052
est-asia@curtisswright.com

2.2. Insert the Injection Tool into one end of the tube to be tested and the Plugging Tool into the other end. Apply enough pressure to seat the Back-up Washer (4) firmly against the end of the tube. Maintain this pressure throughout the test.

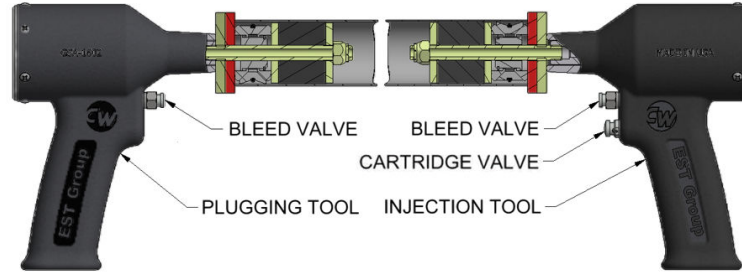

2.3. After making sure that the Plugging Tool operator is ready, press the Cartridge Valve (7) on the Injection Tool and hold until the reading on the Pressure Gauge (11) stabilizes.

2.4. While maintaining control of the Injection Tool by holding on to the handle, release the Cartridge Valve (7). The Cartridge Valve will automatically return to the closed position and isolate the tube being tested. The tube is now under pressure.

NOTE: An initial pressure drop after closing the cartridge valve is normal. This is due to settling of the seals inside the tube and does not indicate a leak.

2.5. Both Injection Tool and Plugging Tool operators should observe the Pressure Gauge (11) on their respective G-160 Tube Testing Tools. Any decrease in the pressure indicated on the Pressure Gauge (11) will indicate a leaking tube. Generally, holding pressure for 5 to 10 seconds will be sufficient to determine whether a tube is leaking. If a leak is detected, follow site specific guidelines for identifying and repairing the tube leak.

2.6. After testing is complete, press the Bleed Valve (8) on the Injection or Plugging Tool to bleed off the air pressure in the tube. Once the pressure is bled off, the Seals will relax.

2.7. Remove the G-160 Tube Testing Tools and move on to the next tube.

2.8. Repeat steps 2.2 through 2.7 for every tube to be tested.

2.9. Disconnect air supply when testing is complete or when not in use.

3. INSTALLING REPLACEMENT SEALS:

Tube size specific Seal and Washer sets are required (ordered separately, see table 2 and 3 for sizing). Replacement Seals for the G-160 Tube Testing Tools are supplied with corresponding size Washers. Always replace the Seals and Washers on both the Injection Tool and the Plugging Tool at the same time.

3.1. Remove the Lock Nut (1) from the end of the Support Tube (5) and set it aside.

3.2. Remove the Seal and Washer Set (2) from the Support Tube (5). Discard if worn. Under optimum testing conditions you should be able to test between 100 and 500 tubes per replacement Seal and Washer Set.

3.3. Remove the Gripper Assembly (3), if applicable (used only for testing tubes with ID's 0.86" and larger)

Questions? Contact EST Group Customer Service at any of the following locations.

**CURTISS-
WRIGHT**

EST Group
www.cw-estgroup.com

North, Central & South America
EST Group Corporate Office
2701 Township Line Road
Hatfield, PA 19440-1770 USA
P: +1.215.721.1100
+1.800.355.7044
F: +1.215.721.1101
est-info@curtisswright.com

Europe / Middle East / Africa
EST Group B.V.
Hoorn 312a
2404 HL Alphen aan den Rijn
The Netherlands
P: +31.172.418841
F: +31.172.418849
est-emea@curtisswright.com

China
P +86.400.636.5077
est-china@curtisswright.cn

Singapore
P +65.3158.5052
est-asia@curtisswright.com

3.4. Install new seal and washer set and gripper assembly (if applicable).

For replacement Seal and Washer sets of the same size, install on Existing Support tube (5). If changing the Seal and Washer set to a different size, the Support Tube Assembly (5) may also need to be changed. To replace the Support Tube Assembly, refer to the procedure outlined in section 4.

3.5. Reinstall and tighten the Lock Nut (1). A small space between the Lock Nut, Seal, Gripper assembly and Washer set, and Back-up Washers is normal.

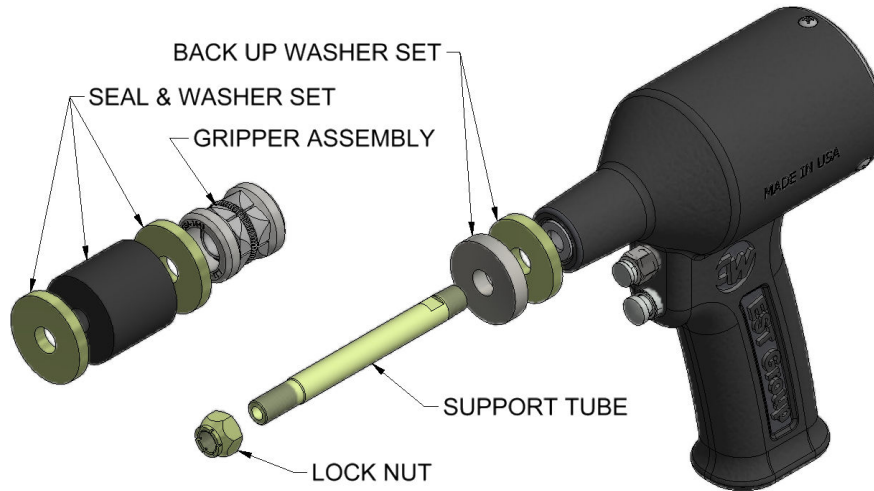

4. REPLACING THE SUPPORT TUBE ASSEMBLY:

The G-160 Tube Testing Tools are originally shipped with GSA-1611 and GSA-1612 Support Tube Assemblies (6). These Support Tube Assemblies allow testing tubes with ID's from 0.49" to 1.11" (12.4 mm to 28.2 mm). Testing tubes with ID's from 0.28"-0.48" (7.1mm-12.2mm) requires GSA-1610 Support Tube Assembly, and for 1.11"-1.81" (28.2mm-46.0mm) required GSA- 1613 or GSA-1614 Support Tube Assemblies (sold separately). Reference Tables 2 and 3 for sizing.

- 4.1. Remove the Seal and Washer Sets, Gripper Assembly (2) and Backup Washer Set (4) as outlined previously.
- 4.2. Using an open end wrench on the wrench flats provided on the Support Tube (5) gently unscrew the Support Tube from the Piston.
- 4.3. Choose the correct size Support Tubes for the tube ID being tested. All three sizes of Support Tubes will fit into the Piston of the G-160 Tube Testing Tool. Use Never-seize or similar product to lubricate and seal the NPT threads. Thread the Support Tube onto G-160 Tube Testing Tool Piston leak tight. Do not over tighten the Support Tube.
- 4.4. Repeat steps 4.1 thru 4.3 for the remaining G-160 Tube Testing Tool.
- 4.5. If testing tube ID's from 0.28" - 0.48" (7.1 mm to 12.2 mm), thread the Regulator Assembly with arrow pointing towards tool onto bottom of the housing handle (using 1/4" NPT nipple) leak tight. Do not over tighten.

Questions? Contact EST Group Customer Service at any of the following locations.

**CURTISS -
WRIGHT**

EST Group
www.cw-estgroup.com

North, Central & South America
EST Group Corporate Office
2701 Township Line Road
Hatfield, PA 19440-1770 USA
P: +1.215.721.1100
+1.800.355.7044
F: +1.215.721.1101
est-info@curtisswright.com

Europe / Middle East / Africa
EST Group B.V.
Hoorn 312a
2404 HL Alphen aan den Rijn
The Netherlands
P: +31.172.418841
F: +31.172.418849
est-emea@curtisswright.com

China
P +86.400.636.5077
est-china@curtisswright.cn

Singapore
P +65.3158.5052
est-asia@curtisswright.com

5. INTERNAL REPLACEMENTS AND REPAIRS:

Contact EST GROUP for additional information.

Table 1: Replacement Parts for G-160 Tube Testing Tool Set (Injection & Plugging Tool)

Item	Quantity	Description	Part Number for Tube ID's Listed				
			in (mm)				
			0.28" - 0.48" (7.1-12.2 mm)	0.49" - 0.86" (12.4 - 21.8 mm)	0.86" - 1.11" (21.8 - 28.2 mm)	1.11"-1.50" (28.2 - 38.1 mm)	1.49" - 1.81" (37.7 - 46.0 mm)
1	1 each tool	Lock Nut	GSA-1530	GSA-1632	GSA-1532		
2	1 set	Seal & Washer Set	GSA-XXXX-N (Neoprene) Refer to Table 2 and 3 to determine sizing and part number				
3	1 each tool	Gripper Assembly	N/A	N/A	GSA-1642	GSA-1643	GSA-1644
4	1 each tool	Back-up Washer Set (includes elastomer & steel washer)	GSA-1520	GSA-1521	GSA-1522	GSA-1623	GSA-1624
5	1 each tool	Support Tube	Supplied as part of item 6				
6	1 each tool	Support Tube Assembly (includes items 1,3,4 &5)	GSA-1610	GSA-1611	GSA-1612	GSA-1613	GSA-1614
7	1	Cartridge Valve (Injection Tool Only)	GSA-1672				
8	1 each tool	Bleed Valve	GSA-1671				
9a	1	Piston Assembly & O-Ring Set (Injection Gun Only)	GSA-1673				
9b	1	Piston Assembly & O-Ring Set (Plugging Gun Only)	GSA-1674				
10	1 each tool	O-Ring Set (also included in Item 9)	GSA-1675				
11a	1 each tool	Pressure Gauge, 0-160 PsiG (0 - 11.03 BarG)	GSA-1540				
11b	1 each tool	Digital Pressure Gauge, 0-145 PsiG (0 - 10.0 BarG)	GSA-1540 D				
12	1 each tool	Spring	N/A				
13	1 each tool	Ring	N/A				
14	1 each tool	Housing	N/A				
15	3 each tool	Screw	N/A				
16	1	Regulator Assembly	GSA-REG	Not required			
16a	1	¼" NPT Hex Nipple					
17	1 each tool (Optional)	Support rod Extension (Available in 1, 2, 3, & 4ft lengths)	GSA-1610-XX	GSA-1611-XX	GSA-1612-XX	GSA-1613-XX	GSA-1614-XX

Questions? Contact EST Group Customer Service at any of the following locations.

**CURTISS -
WRIGHT**

EST Group
www.cw-estgroup.com

North, Central & South America
EST Group Corporate Office
2701 Township Line Road
Hatfield, PA 19440-1770 USA
P: +1.215.721.1100
+1.800.355.7044
F: +1.215.721.1101
est-info@curtisswright.com

Europe / Middle East / Africa
EST Group B.V.
Hoorn 312a
2404 HL Alphen aan den Rijn
The Netherlands
P: +31.172.418841
F: +31.172.418849
est-emea@curtisswright.com

China
P +86.400.636.5077
est-china@curtisswright.cn

Singapore
P +65.3158.5052
est-asia@curtisswright.com

Table 2: Seal & Washer Set Part Numbers

Seal & Washer Set Part Numbers, GSA-XXXX-N, where XXXX is the number listed in the chart for the appropriate tube OD and BWG. Sets for the tube IDs 0.28"-0.48" (7.1-12.3 mm) contain (4) seals and (4) washers. All other Seal and Washer Sets contain (2) seals and (4) washers.

G-160 Seal & Washer Sets, Part Numbers (GSA-XXXX-N)												
BWG	1/2" (12.70 mm)	5/8" (15.88 mm)	3/4" (19.05 mm)	7/8" (22.23 mm)	1" (25.40 mm)	1 1/8" (28.58 mm)	1 1/4" (31.75 mm)	1 3/8" (34.93 mm)	1 1/2" (38.10 mm)	1 5/8" (38.10 mm)	1 3/4" (38.10 mm)	2" (38.10 mm)
8-9	N/A	0030	0043	0056	0068	0081	0093	0106	0118	0131	0143	0168
10-11	N/A	0037	0047	0062	0072	0087	0097	0112	0122	0137	0147	0173
12-13	0028	0040	0053	0065	0078	0090	0103	0115	0128	0140	0153	0178
14-15	0033	0047	0056	0072	0083	0097	0110	0122	0134	0147	0158	
16-17	0037	0050	0062	0075	0087	0100	0112	0126	0137	0150	0162	
18-19	0040	0053	0065	0078	0090	0103	0115	0128	0140	0153	0165	
20-24	0043	0056	0068	0081	0093	0106	0118	0131	0143	0156	0168	

Table 3: G-160 Seal and Washer Sets for Specific Tube ID Ranges.

Part #	ID Range (mm)	ID Range (in)	Support Tube	Part #	ID Range (mm)	ID Range (in)	Support Tube
GSA-0028-N	6.73 - 7.87	0.265 - 0.310	GSA-1610	GSA-0106-N	26.54 - 27.69	1.045 - 1.090	GSA-1612
GSA-0030-N	7.24 - 8.38	0.285 - 0.330	GSA-1610	GSA-0108-N	27.05 - 28.19	1.065 - 1.110	GSA-1612
GSA-0033-N	8.00 - 9.14	0.315 - 0.360	GSA-1610	GSA-0110-N	27.56 - 28.70	1.085 - 1.130	GSA-1613
GSA-0037-N	9.02 - 10.16	0.355 - 0.400	GSA-1610	GSA-0112-N	28.07 - 29.21	1.105 - 1.150	GSA-1613
GSA-0040-N	9.78 - 10.92	0.385 - 0.430	GSA-1610	GSA-0115-N	28.83 - 29.97	1.135 - 1.180	GSA-1613
GSA-0043-N	10.54 - 11.68	0.415 - 0.460	GSA-1610	GSA-0118-N	29.59 - 30.73	1.165 - 1.210	GSA-1613
GSA-0047-N	11.56 - 12.70	0.455 - 0.500	GSA-1610	GSA-0122-N	30.61 - 31.75	1.205 - 1.250	GSA-1613
GSA-0050-N	12.32 - 13.46	0.485 - 0.530	GSA-1611	GSA-0126-NS	31.62 - 32.76	1.245 - 1.290	GSA-1613
GSA-0053-N	13.08 - 14.22	0.515 - 0.560	GSA-1611	GSA-0128-NS	32.13 - 33.27	1.265 - 1.310	GSA-1613
GSA-0056-N	13.84 - 14.99	0.545 - 0.590	GSA-1611	GSA-0131-NS	32.89 - 34.04	1.295 - 1.340	GSA-1613
GSA-0060-N	14.86 - 16.00	0.585 - 0.630	GSA-1611	GSA-0134-NS	33.40 - 34.54	1.315 - 1.360	GSA-1613
GSA-0062-N	15.37 - 16.51	0.605 - 0.650	GSA-1611	GSA-0137-NS	34.42 - 35.56	1.355 - 1.400	GSA-1613
GSA-0065-N	16.13 - 17.27	0.635 - 0.680	GSA-1611	GSA-0140-NS	35.18 - 36.32	1.385 - 1.430	GSA-1613
GSA-0068-N	16.89 - 18.03	0.665 - 0.710	GSA-1611	GSA-0143-NS	35.94 - 37.08	1.415 - 1.460	GSA-1613
GSA-0072-N	17.91 - 19.05	0.705 - 0.750	GSA-1611	GSA-0147-NS	36.96 - 38.10	1.455 - 1.500	GSA-1613
GSA-0075-N	18.67 - 19.81	0.735 - 0.780	GSA-1611	GSA-0150-NS	37.72 - 38.86	1.485 - 1.530	GSA-1614
GSA-0078-N	19.43 - 20.57	0.765 - 0.810	GSA-1611	GSA-0153-NS	38.48 - 39.62	1.515 - 1.560	GSA-1614
GSA-0081-N	20.19 - 21.34	0.795 - 0.840	GSA-1611	GSA-0156-NS	39.24 - 40.39	1.545 - 1.590	GSA-1614
GSA-0083-N	20.70 - 21.84	0.815 - 0.860	GSA-1611	GSA-0158-NS	39.75 - 40.89	1.565 - 1.610	GSA-1614
GSA-0087-N	21.72 - 22.86	0.855 - 0.900	GSA-1612	GSA-0162-NS	40.77 - 41.91	1.605 - 1.650	GSA-1614
GSA-0090-N	22.48 - 23.62	0.885 - 0.930	GSA-1612	GSA-0165-NS	41.53 - 42.67	1.635 - 1.680	GSA-1614
GSA-0093-N	23.24 - 24.38	0.915 - 0.960	GSA-1612	GSA-0168-NS	42.29 - 43.43	1.665 - 1.710	GSA-1614
GSA-0097-N	24.26 - 25.40	0.955 - 1.000	GSA-1612	GSA-0173-NS	43.56 - 44.70	1.715 - 1.760	GSA-1614
GSA-0100-N	25.02 - 26.16	0.985 - 1.030	GSA-1612	GSA-0178-NS	44.83 - 45.97	1.765 - 1.810	GSA-1614
GSA-0103-N	25.78 - 26.92	1.015 - 1.060	GSA-1612				

Note: For GSA-0028 to GSA-0047: Test pressure must be regulated between 40 and 60 PsiG (2.76 to 4.14 BarG). Do not exceed 60 PsiG (4.14 BarG).

Questions? Contact EST Group Customer Service at any of the following locations.

**CURTISS-
WRIGHT**

EST Group
www.cw-estgroup.com

North, Central & South America
EST Group Corporate Office
2701 Township Line Road
Hatfield, PA 19440-1770 USA
P: +1.215.721.1100
+1.800.355.7044
F: +1.215.721.1101
est-info@curtisswright.com

Europe / Middle East / Africa
EST Group B.V.
Hoorn 312a
2404 HL Alphen aan den Rijn
The Netherlands
P: +31.172.418841
F: +31.172.418849
est-emea@curtisswright.com

China
P +86.400.636.5077
est-china@curtisswright.cn

Singapore
P +65.3158.5052
est-asia@curtisswright.com

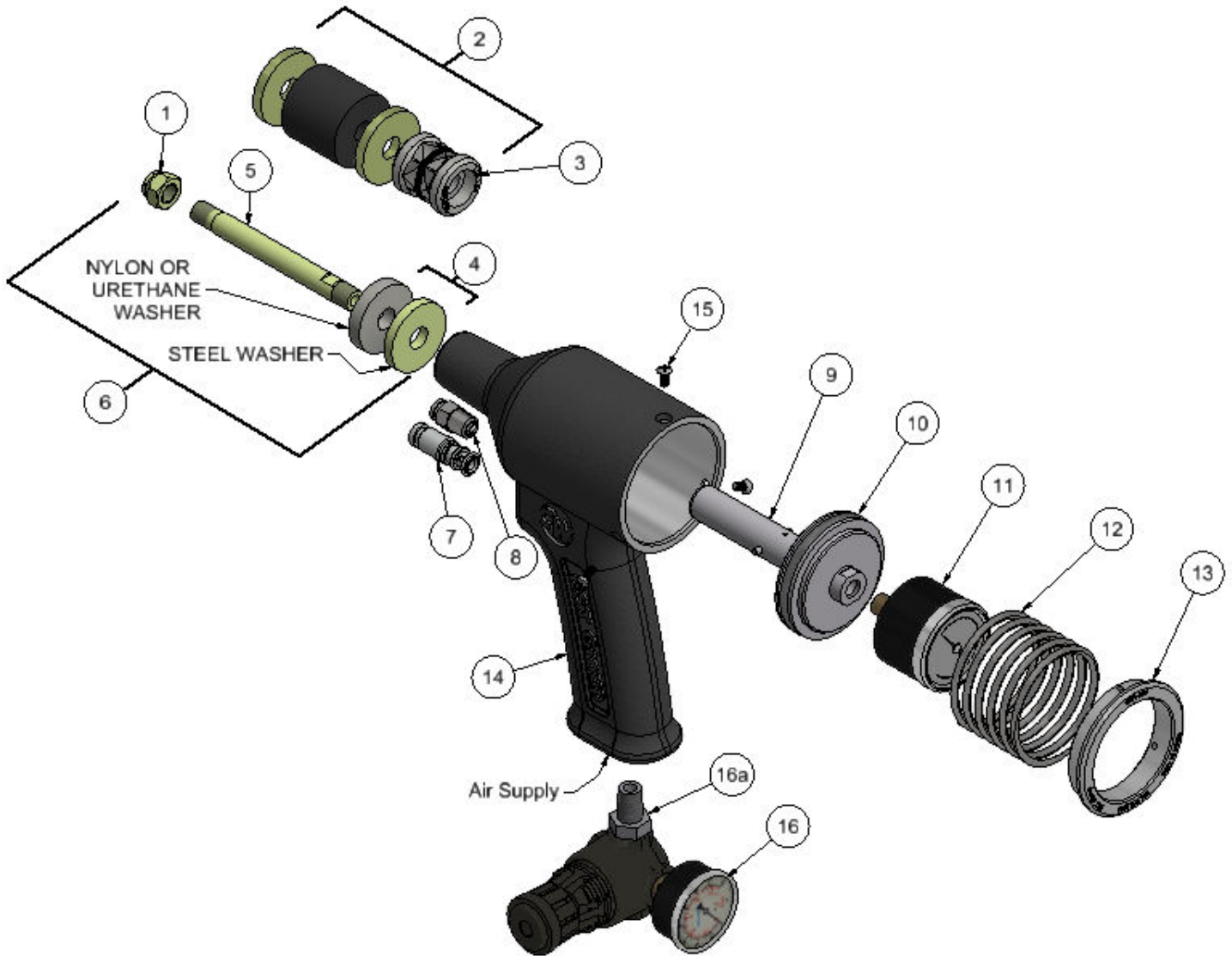

Figure 1: G-160 injection Tool

Questions? Contact EST Group Customer Service at any of the following locations.

**CURTISS-
WRIGHT**

EST Group
www.cw-estgroup.com

North, Central & South America
EST Group Corporate Office
2701 Township Line Road
Hatfield, PA 19440-1770 USA
P: +1.215.721.1100
+1.800.355.7044
F: +1.215.721.1101
est-info@curtisswright.com

Europe / Middle East / Africa
EST Group B.V.
Hoorn 312a
2404 HL Alphen aan den Rijn
The Netherlands
P: +31.172.418841
F: +31.172.418849
est-emea@curtisswright.com

China
P +86.400.636.5077
est-china@curtisswright.cn

Singapore
P +65.3158.5052
est-asia@curtisswright.com

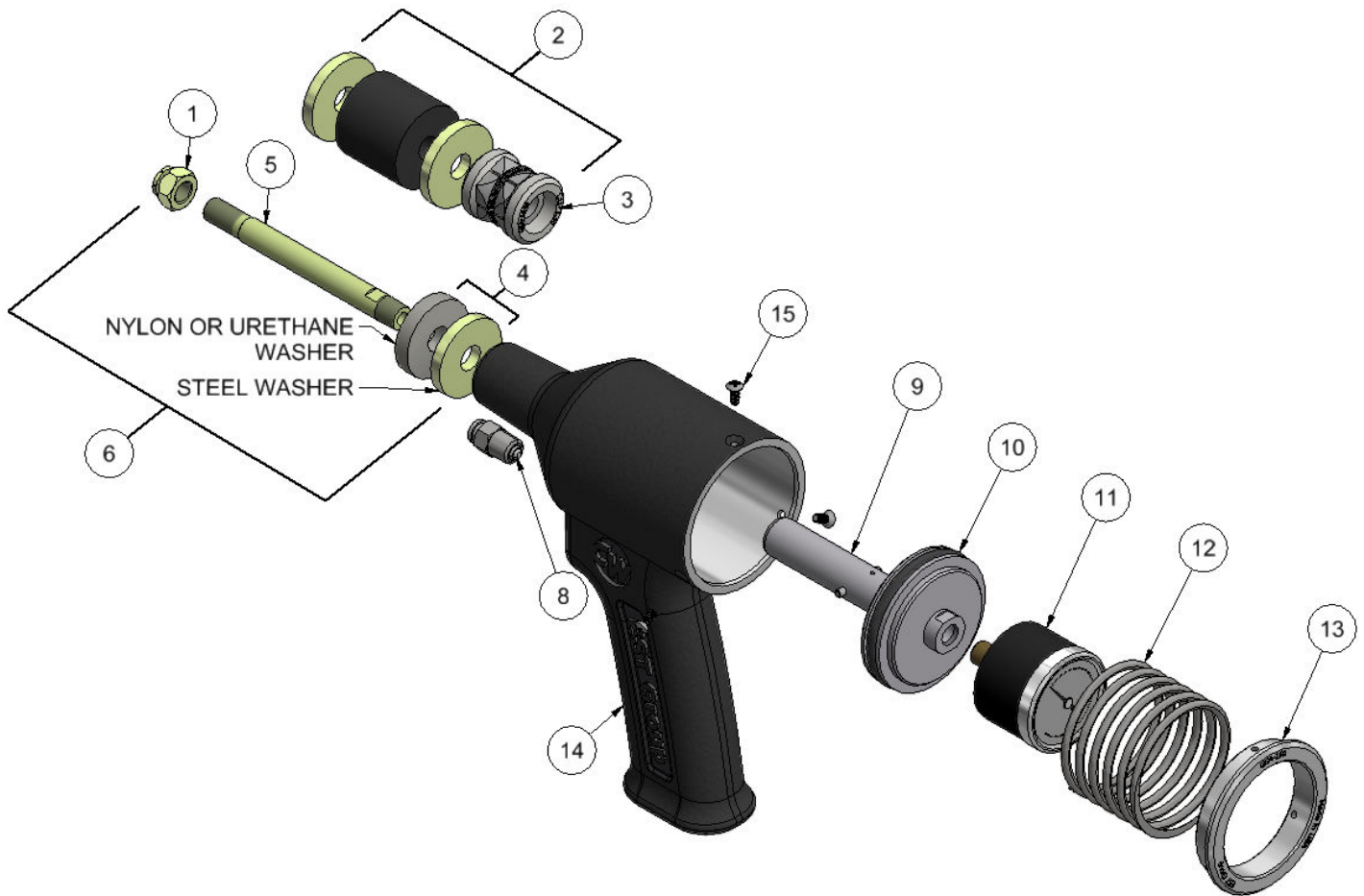

Figure 2: G-160 Plugging Tool

Questions? Contact EST Group Customer Service at any of the following locations.

**CURTISS-
WRIGHT**

EST Group
www.cw-estgroup.com

North, Central & South America
EST Group Corporate Office
2701 Township Line Road
Hatfield, PA 19440-1770 USA
P: +1.215.721.1100
+1.800.355.7044
F: +1.215.721.1101
est-info@curtisswright.com

Europe / Middle East / Africa
EST Group B.V.
Hoorn 312a
2404 HL Alphen aan den Rijn
The Netherlands
P: +31.172.418841
F: +31.172.418849
est-emea@curtisswright.com

China
P +86.400.636.5077
est-china@curtisswright.cn

Singapore
P +65.3158.5052
est-asia@curtisswright.com

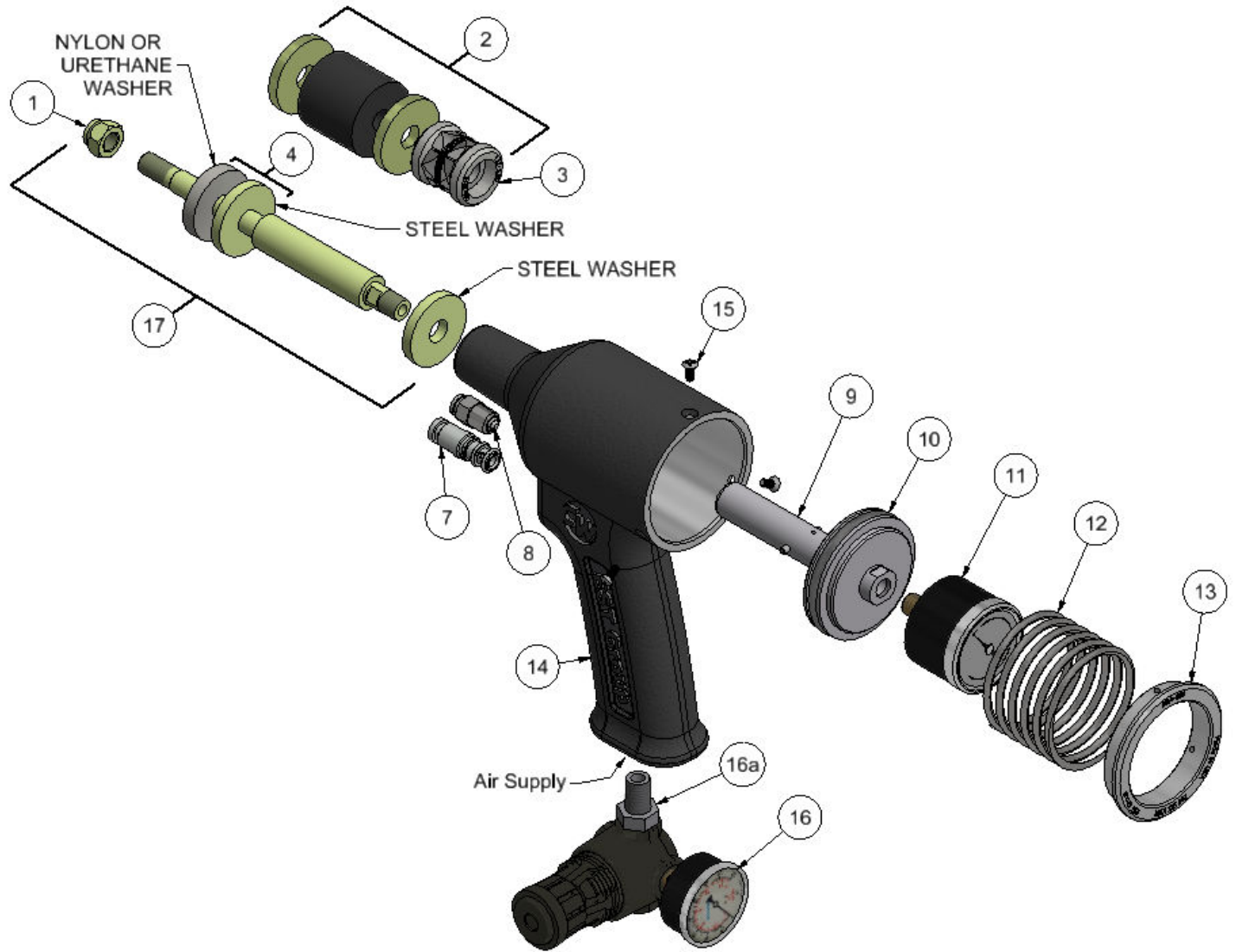

Figure 3: G-160 Injection Tool (Shown with Optional Support Rod Extension)

Questions? Contact EST Group Customer Service at any of the following locations.



EST Group
www.cw-estgroup.com

North, Central & South America
EST Group Corporate Office
 2701 Township Line Road
 Hatfield, PA 19440-1770 USA
 P: +1.215.721.1100
 +1.800.355.7044
 F: +1.215.721.1101
est-info@curtisswright.com

Europe / Middle East / Africa
EST Group B.V.
 Hoorn 312a
 2404 HL Alphen aan den Rijn
 The Netherlands
 P: +31.172.418841
 F: +31.172.418849
est-emea@curtisswright.com

China
 P +86.400.636.5077
est-china@curtisswright.cn

Singapore
 P +65.3158.5052
est-asia@curtisswright.com