

Pop-A-Plug® CPI/Perma Heat Exchanger Tube Plugs

Safe & Reliable Solution to Seal Leaking Heat Exchanger & Condenser Tubes

Resistant to thermal cycling and able to provide a seal that's helium-leak tight, Pop-A-Plug CPI/Perma Tube Plugs are the safe, effective, and reliable solution for heat exchanger tube leaks. Pop-A-Plug CPI/Perma Tube Plugs are rated to 1000 PsiG (68.9 BarG), and install in minutes. Their broad expansion range fits multiple gauges reducing inventory and costs. Controlled and repeatable installation minimizes installer fatigue and protects against damage to tubesheet ligaments and adjacent tubesheet joints, extending the life of heat exchangers and reducing costs for retubing. Kits include ten (10) plugs and one (1) Go/No-Go Gage.

Pressure Rating

Up to 1000 PsiG (68.9 BarG) - *Higher pressures available upon request*

Size Range

0.472" to 2.067" (11.99mm to 52.5mm) Tube ID - *Larger/smaller sizes available upon request*

Standard Materials

Brass, Carbon Steel, 304/316 Stainless Steel, 70/30 CuNi, Titanium

Additional materials available, partial list below - contact Customer Service for full list

Features & Benefits

- Eliminates welding and/or explosives
- Simple hydraulic installation significantly reduces turnaround/down time
- Provides Helium leak tight seal to 1×10^{-6} cc/sec
- Recommended repair method per ASME PCC-2 (Article 312)*
- Metal to metal seal will not leak or degrade like elastomer plugs
- Lowest lifecycle cost compared to alternative tube plugging methods
- 24/7 Emergency manufacturing available

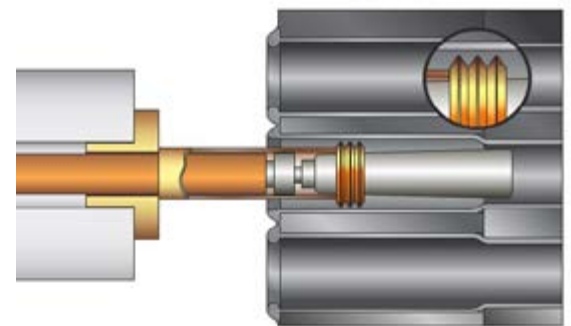

For additional installation and sizing information, please reference:

- [DC1220 - Pop-a-Plug CPI/Perma Near End Installation Procedure](#)
- [DC4015 - Pop-a-Plug CPI/Perma Through-the-Tube Installation Procedure](#)

Additional materials: Chromoly F9 & F11, AL6XN, SS 317L/321/347, SS 400 Series Alloys, SS 904L, SS 254 SMO, SS 20CB3/Alloy 20, Super Duplex SS, Inconel Alloys, Incoloy Alloys, Hastelloy Alloys, Nickel 200/201, Zirconium, Carbon Steel A350 LF2

* *Inspection and Repair of Shell and Tube Heat Exchangers, The American Society of Mechanical Engineers (ASME) PCC-2, Article 312.*

North, Central & South America EST Group 2701 Township Line Road Hatfield, PA 19440-1770 USA | +1.215.721.1100 +1.800.355.7044 | est-info@curtisswright.com

Europe / Middle East / Africa EST Group B.V. Hoorn 312D 2404 HL Alphen aan den Rijn The Netherlands | +31.172.418841 | est-emea@curtisswright.com

China +86.400.636.5077 | est-china@curtisswright.cn | **Singapore** +65.3158.5052 | est-asia@curtisswright.com