

## Pop-a-Plug® Manual Installation Tool

### Reliable Manual Installations

Provides reliable installation in situations where air or electricity are not available. Each Manual Installation Tool (MIT) comes complete with a Pull Rod and Positioner to install the size and style Pop-A-Plug Tube Plug identified in the tool's model number. Can be used with manual wrenches or sockets, as well as with electric or pneumatic impact wrenches.

#### Size Range

.471" to 1.149" (11.96 to 29.18mm) - CPI/Perma Plugs

.400" to 1.160" (10.16 to 29.46mm) - P2 Plugs

#### Standard Material

Zinc Plated Carbon Steel

#### Features

- Provides fast, reliable installation where air or electricity are not available
- Standard body accepts all MIT pull rods and positioners
- Locating pin acts as a reaction arm to prevent the body from spinning as the Hex Nut is being tightened

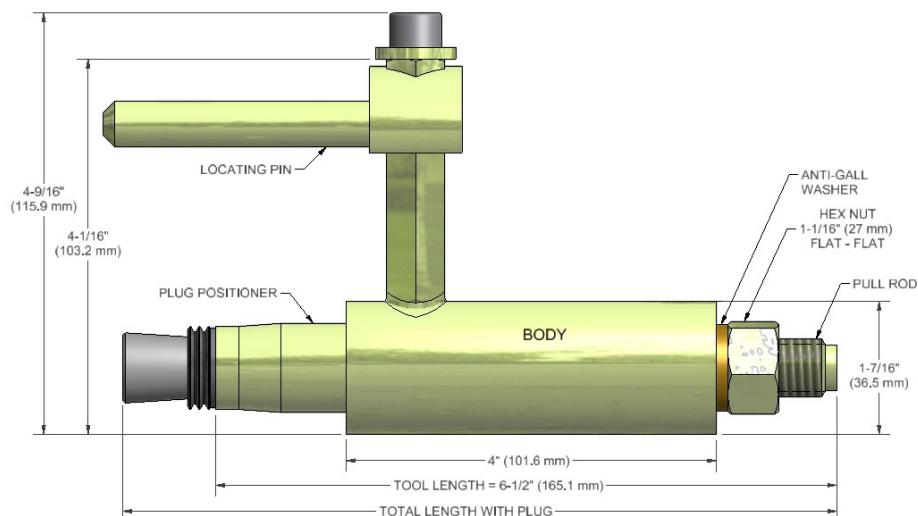

## Manual Installation Tools for CPI/Perma Plugs

PART NUMBER	CPI SIZE	TOTAL LENGTH WITH PLUG	PULL ROD	PLUG POSITIONER	Body & LOCATING PIN	LOCATING PIN
MIT-V-471	.471	7-7/8"(200.0 mm)	MPR-1228	MPP-V-471	MBDY-1	MITLP-01
MIT-V-491	.491	7-7/8" (200.0 mm)	MPR-1228	MPP-V-491	MBDY-1	MITLP-01
MIT-V-512	.512	7-13/16" (198.4 mm)	MPR-1228	MPP-V-512	MBDY-1	MITLP-01
MIT-V-524	.524	7-13/16" (198.4 mm)	MPR-1228	MPP-V-524	MBDY-2	MITLP-02
MIT-V-555	.555	7-15/16"(201.6 mm)	MPR-1228	MPP-V-555	MBDY-2	MITLP-02
MIT-V-584	.584	7-7/8" (200.0 mm)	MPR-0428	MPP-V-584	MBDY-2	MITLP-02
MIT-V-621	.621	8-1/8" (206.4 mm)	MPR-0428	MPP-V-621	MBDY-2	MITLP-02
MIT-V-649	.649	7-7/8" (200.0 mm)	MPR-0428	MPP-V-649	MBDY-2	MITLP-02
MIT-V-670	.670	8-3/16" (208.0 mm)	MPR-0428	MPP-V-670	MBDY-2	MITLP-02
MIT-V-712	.712	7-7/8" (200.0 mm)	MPR-0428	MPP-V-712	MBDY-2	MITLP-02
MIT-V-735	.735	8-3/16" (208.0 mm)	MPR-0428	MPP-V-735	MBDY-2	MITLP-02
MIT-V-774	.774	7-7/8" (200.0 mm)	MPR-0524	MPP-V-774	MBDY-2	MITLP-02
MIT-V-804	.804	8-1/4" (209.6 mm)	MPR-0524	MPP-V-804	MBDY-2	MITLP-02
MIT-V-837	.837	7-7/8" (200.0 mm)	MPR-0524	MPP-V-837	MBDY-2	MITLP-02
MIT-V-853	.853	8-1/4" (209.6 mm)	MPR-0524	MPP-V-853	MBDY-2	MITLP-02
MIT-V-899	.899	7-7/8" (200.0 mm)	MPR-0524	MPP-V-899	MBDY-2	MITLP-02
MIT-V-919	.919	8-1/4" (209.6 mm)	MPR-0524	MPP-V-919	MBDY-2	MITLP-02
MIT-V-962	.962	7-7/8" (200.0 mm)	MPR-0524	MPP-V-962	MBDY-2	MITLP-02
MIT-V-979	.979	8-3/8" (212.7 mm)	MPR-0524	MPP-V-979	MBDY-2	MITLP-02
MIT-V-1024	1.024	7-7/8" (200.0 mm)	MPR-0524	MPP-V-1024	MBDY-2	MITLP-02
MIT-V-1054	1.054	8-7/16" (214.3 mm)	MPR-0524	MPP-V-1054	MBDY-2	MITLP-02
MIT-V-1087	1.087	7-7/8" (200.0 mm)	MPR-0524	MPP-V-1087	MBDY-2	MITLP-02
MIT-V-1103	1.103	8-7/16" (214.3 mm)	MPR-0524	MPP-V-1103	MBDY-2	MITLP-02
MIT-V-1149	1.149	7-7/8" (200.0 mm)	MPR-0524	MPP-V-1149	MBDY-2	MITLP-02

## Manual Installation Tools for P2 Plugs

PART NUMBER	P2 PLUG SIZES	TOTAL LENGTH WITH PLUG	PULL ROD	PLUG POSITIONER	Body & LOCATING PIN	LOCATING PIN
MIT-P2-400-440	.400-.440"	8-3/8 " (212.7 mm)	MPR-1032	MPP-P2-400-440	MBDY1	MITLP-01
MIT-P2-460-500	.460-.500"	8-3/8 " (212.7 mm)	MPR-1228	MPP-P2-460-500	MBDY1	MITLP-01
MIT-P2-520-580	.520-.580"	8-3/8 " (212.7 mm)	MPR-1228	MPP-P2-520-580	MBDY2	MITLP-02
MIT-P2-600-680	.600-.680"	8-3/8 " (212.7 mm)	MPR-0428	MPP-P2-600-680	MBDY2	MITLP-02
MIT-P2-700-780	.700-.780"	8-3/8 " (212.7 mm)	MPR-0428	MPP-P2-700-780	MBDY2	MITLP-02
MIT-P2-800-860	.800-.860"	8-3/8 " (212.7 mm)	MPR-0428	MPP-P2-800-860	MBDY2	MITLP-02
MIT-P2-880-960	.880-.960"	8-3/8 " (212.7 mm)	MPR-0524	MPP-P2-880-960	MBDY2	MITLP-02
MIT-P2-980-1060	.980-1.060"	8-3/8 " (212.7 mm)	MPR-0524	MPP-P2-980-1060	MBDY2	MITLP-02
MIT-P2-1080-1160	1.080-1.160"	8-3/8 " (212.7 mm)	MPR-0524	MPP-P2-1080-1160	MBDY2	MITLP-02

**North, Central & South America EST Group** 2701 Township Line Road Hatfield, PA 19440-1770 USA | +1.215.721.1100 +1.800.355.7044 | est-info@curtisswright.com

**Europe / Middle East / Africa EST Group B.V.** Hoorn 312D 2404 HL Alphen aan den Rijn The Netherlands | +31.172.418841 | est-emea@curtisswright.com

**China** +86.400.636.5077 | est-china@curtisswright.cn | **Singapore** +65.3158.5052 | est-asia@curtisswright.com