

Condenser Plug Change Out - Plug Leaking Tubes with Pop-A-Plug® Tube Plugs



Target Plant Type

- Power
- Nuclear
- Conventional
- Large
- Older (>10 years old)

Target Personnel

- Maintenance Managers
- System Engineers
 - Feedwater
 - Condensate
 - Circulating Water
- Outage Planners
- Plant Chemists

Target Equipment

- Condensers
- Surface Condensers

Main Condensers are used in conventional, nuclear, and combined cycle power stations. Their primary function is to collect waste steam and reintroduce condensate back into the feedwater system. When tube leaks occur (through corrosion or leaking plugs), raw cooling water mixes with steam plant clean water leading to premature failure of critical and extremely expensive equipment.

Many plants use elastomer/polymer plugs as a quick fix for leaking tubes, however elastomer/polymer tube plugs have been shown to deteriorate over time leading to lost and leaking plugs¹. Pop-A-Plug® Tube Plugging System offers a perfect solution to plants looking for a reliable permanent, yet removable engineered solution for repairing leaking or degraded condenser tubes.

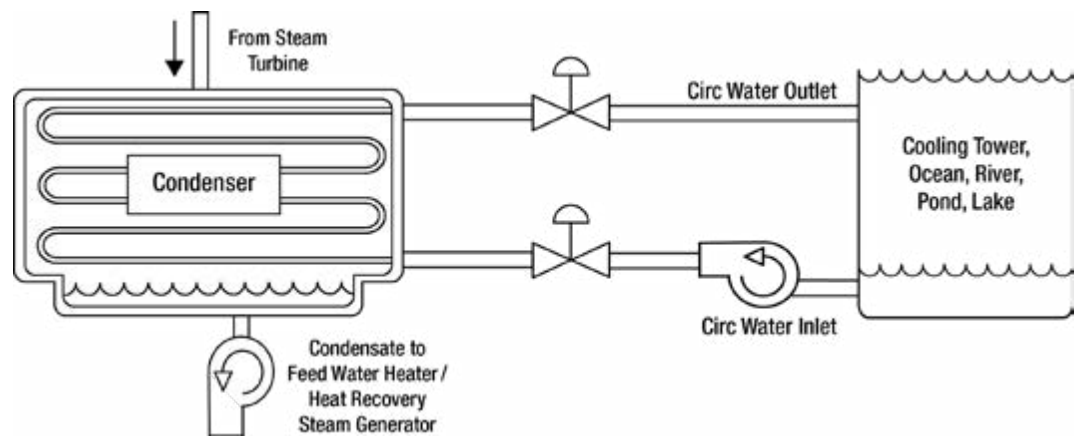

Equipment Specification Range for Most Condensers

Tube Size	3/4" through 1 1/4" (19.05mm to 31.75mm)
Tube Length	20 to 150 ft. (6.1 to 45.7m)
Tube Quantity	8,000 to 40,000 tubes
Tube Material	Copper based alloys, Austenitic and Super Austenitic Stainless Steels, Ferritic Stainless Steels, Titanium

Pop-A-Plug® CPI/Perma - Stats & Features

Pressure Rating up to 1000 PsiG (68.9 BarG) - *higher pressures available upon request*

Size Range 0.472" to 2.067" (11.99mm - 52.5mm) Tube I.D. - *larger/smaller sizes available upon request*

Stock Materials Brass, Carbon Steel, 304/316 Stainless Steel, 70/30 CuNi - *additional material available, please contact Customer Service for full list*

Features

- Metal to metal seal will not leak or degrade like elastomer plugs
- Plug material matches tube material - preventing thermal expansion and contraction issues and undesirable galvanic interaction
- Helium leak tight seal to 1×10^{-6} cc/sec
- Engineered solution - installed with controlled force eliminating ligament and/or roll joint damage
- Lowest life-cycle cost compared to alternative tube plugging methods
- Hydraulic installation significantly reduces turnaround/down time
- Eliminates need for welding or explosives



Top 5 Reasons to Replace Elastomer/Polymer Plugs with Pop-A-Plug® Tube Plugs

- You have leaking condenser plugs resulting in cooling water inleakage, causing increased forced outage hours
- You have experienced increased water chemistry costs attributed to inleakage
- You have had secondary equipment failures caused by inleakage
- You have incurred increased costs to identify leaking or compromised tube plugs
- You have had Loss of Offsite Power (LOOP) events (Nuclear Power Plants) and the elastomer plugs you are using are degrading and expelling

What Makes Pop-A-Plug® Tube Plugs Uniquely Suited for Power Plant Applications?

1. Reliable Tube Plugging Solution

- Metal-to-metal seal eliminates welding
- Will not degrade like elastomer/polymer plugs
- Helium leak tight seal to 1×10^{-6} cc/sec
- Will not damage tube or tubesheet joints like hammer in plugs
- Controlled and repeatable installation
- Safe to use in application with epoxy coated tubes and/or tubesheets

2. **Maximizes Plant Uptime** – by combining speed of installation and long term performance, Pop-A-Plug Tube Plugs minimize downtime due to lengthy repairs, rework, and chasing lost or leaking plugs.

3. **Provides Lowest Life-cycle Cost** – compared to alternative plugging methods.

4. **Eliminates Corrosion & Thermal Concerns** – matching plug to tube material eliminates corrosion and differences in thermal coefficients of expansion.

5. **Readily Available** – we maintain a large inventory; 24/7 emergency manufacturing capability. Ask about our Outage Job Box Program.

6. **Industry Reputation** – used at more than 95% of US Nuclear Power Plants (NPPs), Canadian NPPs, French NPPs, US Navy Carriers and Submarines.

7. **LOOP Tolerant** – pressure rating safety factors in excess of 10 times – easily handles pressure upset occurring during nuclear power plant LOOP or Station Black Out (SBO) events.

Quality Assurance / Product Approvals

- Material Traceability - full material traceability on each individual plug
- Manufactured in an ISO 9001:2015 registered facility
- Third party evaluation and approval by TUV and others
- Meets or exceeds **EPRI Condenser Plug Selection Criteria**²
- **US Navy Approved** - Quality Program to Navy Level 1
- **Canadian CRN approvals**
- Meets ASME PCC-2 Article 312 requirements & ASME Boiler and Pressure Vessel Codes
- Compliant with QA Systems, including; ANSI N45.2, NQA-1, 10 CFR 50 App. B, 10 CFR 21, and TÜV Rheinland



1. Main Condenser Cooling Water Inleakage, Institute of Nuclear Power Operations (INPO), 2013, INPO Event Report L4-13-17

2. Condenser In-Leakage Guideline, Electric Power Research Institute (EPRI), Palo Alto, CA, 2000, TR-112819 Page 7-2.